

Flexitallic[®]

COMPRESSION PACKINGS

The choice for
valves and pumps.



FLEXITALLIC

The Flexitallic Group is the international market leader in the manufacture and supply of high quality, high value industrial static sealing products.



About us

As the developer of the spiral wound gasket in 1912, we have built on this legacy of innovation with revolutionary products including Thermiculite[®] and Sigma[®], The Flange Rescue Gasket, and most recently the Change[™] Gasket, set to transform the global sealing industry.

We have a global network of Allied Distributors across 30 countries. This ensures local demand is met quickly, providing a combination of the highest product quality and outstanding customer service.

Our extensive and varied product offering includes spiral wound gaskets, RTJ gaskets, Flexpro[™] Kammprofiles, sheet materials, dynamic and static packings, pipe support and custom rubber products. Drawing upon the group's rich history and present day values of safety, quality, continuous improvement, teamwork, integrity and performance, we are at the forefront of developing sealing solutions for industries around the world.

In addition to a wide range of products, we also deliver world-class technical support and Joint Integrity training.

Our Mission

Making the world safer and cleaner through engineered sealing solutions.



Based on sales and geographic reach, the Flexitallic Group has become *the* global supplier of industrial seals.

Innovative Product Range

We have a rich history of innovation, which has seen us lead the industry with many new products.

Over the years, our products have gained a reputation for quality, reliability and technology that is second to none.

Customised Engineering Solutions

Our Application Engineering, Production Engineering and R&D teams work closely together to design, develop and manufacture bespoke sealing solutions.

We have been responsible for a number of truly revolutionary products, including Thermiculite®, Sigma® and the Flange Rescue Gasket, which ensure we are able to continually meet the ever more stringent requirements of our customers.

Flexitallic® Safe

Over the last century, our aggressive R&D efforts have helped customers become Flexitallic® Safe. From the first Spiral Wound Gasket in 1912 to the ever evolving applications for Thermiculite®, our goal is to develop materials that push the parameters of heat, pressure and chemical resistance.

Our Commitment to Quality

We place great emphasis on maintaining international quality standards, and are approved to ISO 9001:2008, ISO 14001:2004 and OHSAS 18001:2007, API 6A and API 17D, to ensure we meet the highest possible standards for all our products and services.

We also invest heavily in test and quality assurance equipment to maintain our reputation for the highest quality products.

Our materials are subjected to a wide range of tests as specified by statutory regulations and customer requirements. These approvals enable our customers to make informed choices as to the suitability of a product for each and every application.

Inside Industry

We pride ourselves on not simply supplying products, but by supporting customers with a detailed knowledge of their industry and applications, so that products and services are tailored to their specific needs.

This unique approach means that we focus on providing more than just a product, but also a complete solution that adds genuine value to our clients.

Global Distribution... Local Support

Our products are distributed through a global network of Allied Distributors.

These carefully selected distribution partners are strategically located within their territory to deliver the best possible service and products to our customers. This approach means our products and know-how are available to the global industries we service.

Allied Distributor



Licensee Manufacturer



COMPRESSION PACKING RANGE SUMMARY

STYLE	MATERIAL	CONSTRUCTION	EQUIPMENT SERVICE				PAGE
			ROTARY	RECIP.	VALVE	STATIC	
26D	Pure PTFE yarn.	X-Braid	-	-	Y	Y	4
26L	Pure PTFE yarn impregnated with PTFE dispersion and silicone-free lubricant.	X-Braid	Y	-	Y	-	4
45	High quality Cotton yarn heavily greased and graphited.	Square-Braid	Y	Y	Y	-	5
50	Ramie yarn heavily impregnated with PTFE.	X-Braid	Y	Y	Y	-	5
304	High quality Carbon fibre impregnated with high performance lubricant, corrosion inhibitors and sacrificial zinc. Reinforced with Inconel® wire.	X-Braid	Y	Y	Y	-	6
305	High purity exfoliated Graphite.	Square-Braid	Y	Y	Y	-	6
306	High purity exfoliated Graphite, reinforced with Inconel® wire.	Square-Braid	-	-	Y	Y	7
308	High purity exfoliated Graphite over knitted with Inconel® wire, contains high temperature corrosion inhibitor. Fugitive Emissions Packing .	Square-Braid	-	-	Y	Y	7
310	High quality Carbon filament reinforced Graphite tape, with a secondary reinforcement using additional strands of Carbon yarn.	X-Braid	Y	Y	Y	-	8
713L	Air textured continuous filament Glass yarns impregnated with PTFE dispersion and high quality break-in lubricant.	X-Braid	Y	Y	Y	-	8
774	Continuous filament Glass yarn impregnated with mineral oil and graphite.	X-Braid	Y	Y	Y	-	9
801	Graphite impregnated PTFE yarn with reinforced multi-filament Aramid yarn corners.	X-Braid	Y	Y	-	-	9
802	White PTFE yarn with reinforced multi-filament Aramid yarn corners.	X-Braid	Y	Y	Y	-	10
803	Acrylic yarns impregnated with PTFE dispersion and high quality break-in lubricant.	X-Braid	Y	-	Y	-	10
900	Graphite filled PTFE yarns with high temperature lubricant. *GFO yarn variant available if required – style 1065	X-Braid	Y	Y	Y	-	11
2001	High strength Aramid yarn with PTFE dispersion and high temperature lubricant.	X-Braid	Y	Y	Y	-	11
GP1	High density continuous filament 'E' Glass yarn.	Rope	-	-	-	Y	12
GP2	Medium density continuous filament 'E' Glass yarn.	Rope	-	-	-	Y	12
GP125	Low density continuous filament 'E' Glass yarn.	Rope	-	-	-	Y	12
TH894	Expanded Thermiculite® foil and Inconel® wire.	Square-Braid	-	-	-	Y	13

*GFO is a trademark of WL Gore & Associates Inc
Inconel® is a trademark of Special Metals

Other Packing styles available on request. Please contact customerservice@flexitallic.eu

COMPRESSION PACKING RANGE SUMMARY

TYPICAL APPLICATIONS	TEMPERATURE °C (°F)		PRESSURE - MPa (psi)		SHAFT SPEED		pH RANGE
	Min.	Max.	Rotary	Valve	m/s	fpm	
FDA compliant. Chemical, food, pharmaceutical, oxygen, petrochemical and brewing industries.	-100 (-148)	260 (500)	2 (290)	20 (2900)	3	590	0 - 14
FDA compliant. Chemical, food, pharmaceutical, petrochemical and brewing industries.	-100 (-148)	250 (482)	7 (1015)	20 (2900)	8	1575	0 - 14
General service.	-20 (-5)	120 (248)	2.5 (365)	7 (1015)	5	984	5 - 9
FDA compliant. Potable water, cold and warm fresh and sea water, solutions with solids.	-40 (-40)	120 (248)	4 (580)	7 (1015)	13	2559	5 - 11
Steam applications in power generation, petrochemical, chemical, oil & gas applications.	-50 (-58)	430 (806)	2.5 (362)	20 (2900)	20	3937	0 - 14
High pressure and high temperature pumps and valves in the petrochemical, chemical, oil and gas industry.	-200 (-328)	460 (860)	2.5 (362)	20 (2900)	20	3937	0 - 14
High pressure and high temperature valves in the petrochemical, chemical, oil and gas industry.	-200 (-328)	460 (860)	2.5 (362)	30 (4350)	1	197	0 - 14
Low emission packing for high temperature valves in the oil & gas, petrochemical, chemical industry.	-200 (-328)	460 (860)	2.5 (362)	45 (6525)	1	197	0 - 14
Particularly suitable for power generation steam valves, boiler feed and other condensate pumps.	-50 (-58)	430 (806)	2.5 (362)	45 (6525)	2 (valve) 20 (pump)	394 (valve) 3937 (pump)	0 - 14
Petrochemical, food, paint and brewing industries. Particularly suitable for mine de-watering pumps.	-85 (-120)	290 (554)	14 (2030)	10 (1450)	10	1969	3 - 12
Petrochemical industry and general industrial pumps and valves.	-85 (-120)	480 (896)	14 (2030)	10 (1450)	10	1969	3 - 12
Most suited for rotary and plunger pumps in a wide range of chemical applications. Thermally conductive.	-50 (-58)	280 (536)	2.5 (362)	n/a	25	4921	1 - 13
Most suited for rotary and plunger pumps in a wide range of chemical and abrasive media applications.	-50 (-58)	280 (536)	2.5 (362)	25 (3625)	20	3937	2 - 13
Suitable for contact with food and potable water and mild chemicals in general industrial applications.	-50 (-58)	150 (302)	2 (290)	10 (1425)	12	2362	2 - 12
Suitable for pumps and valves in the petrochemical, chemical, brewing, paper and pulp industries.	-85 (-120)	260 (500)	2 (290)	20 (2900)	20	3937	0 - 14
Particularly recommended for pumping abrasive slurries. Also suited for water, steam, solvents and fuel oils.	-85 (-120)	260 (500)	2 (290)	25 (3625)	15	2953	2 - 12
Static seals in metal processing applications, boiler doors, furnace doors, coal and wood burning stove door seals.	n/a	600 (1112)	n/a	n/a	n/a	n/a	5 - 11
	n/a	600 (1112)	n/a	n/a	n/a	n/a	5 - 11
	n/a	600 (1112)	n/a	n/a	n/a	n/a	5 - 11
Particularly suitable for large diameter flanges on high temperature reactors and pressure vessels.	n/a	1050 (1900)	n/a	n/a	n/a	n/a	0 - 14

KEY



VALVE



ROTARY



OVEN DOOR SEAL



FLEXITALLIC 26D

Flexitallic 26D compression packing is a soft packing, constructed by X-braiding pure PTFE yarn.

Flexitallic 26D can be used in valve or static applications handling most chemical media. It is especially used in applications involving concentrated acids or where non-contamination of the product is required. The relatively soft and conformable nature of Flexitallic 26D enables sealing to be achieved with minimum gland pressure. Typical sealing applications include aggressive chemicals, foodstuffs and pharmaceuticals.

Properties

Materials of construction: Pure PTFE yarn.

Colour – White

Typical Applications

Valves, slow acting control valves and pumps, door seals. FDA compliant. Suitable for gaseous oxygen service (3MPa up to 60°C)

Temperature

Maximum: 260°C (500°F)

Minimum: -100°C (-148°F)

Pressure

Maximum: Rotating – 2MPa (290 psi)

Valve – 20MPa (2900 psi)

Reciprocating – 15MPa (2174 psi)

Speed

Maximum: Rotating – 3 m/s (590 fpm)

Valve – 2 m/s (394 fpm)

Reciprocating – 1 m/s (197 fpm)

pH Range

0 – 14

Standard Sizes (mm sq.)

3.2, 5.0 – 20m spools.

6.5, 8.0, 9.5, 12.5, 14.0, 16.0, 19.0, 22.0, 25.0 – 8m spools

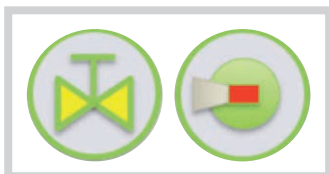

FLEXITALLIC 26L

Flexitallic 26L compression packing is a soft packing, constructed by X-braiding pure PTFE yarn impregnated with PTFE dispersion and silicone-free lubricant.

Flexitallic 26L can be used in rotary and reciprocating applications handling most chemical media. It is especially used in applications involving concentrated acids or where non-contamination of the product is required. The relatively soft and conformable nature of Flexitallic 26L enables sealing to be achieved with minimum gland pressure. Typical sealing applications include aggressive chemicals, foodstuffs and pharmaceuticals.

Properties

Materials of construction: Pure PTFE yarn impregnated with silicone-free lubricants.

Colour – White

Typical Applications

Pumps, mixers and control valves. FDA compliant.

Temperature

Maximum: 250°C (482°F)

Minimum: -100°C (-148°F)

Pressure

Maximum: Rotating – 2MPa (290 psi)

Valve – 20MPa (2900 psi)

Reciprocating – 15MPa (2174 psi)

Speed

Maximum: Rotating – 8 m/s (1575 fpm)

Valve – 2 m/s (394 fpm)

Reciprocating – 2 m/s (394 fpm)

pH Range

0 – 14

Standard Sizes (mm sq.)

3.2, 5.0 – 20m spools.

6.5, 8.0, 9.5, 12.5, 14.0, 16.0, 19.0, 22.0, 25.0 – 8m spools

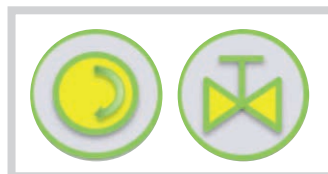



FLEXITALLIC 45

Flexitallic 45 compression packing is a soft packing, constructed by square braiding high quality cotton yarn, heavily greased and graphited.

Flexitallic 45 can be used in both valve and pump applications. It is especially suitable for use in less demanding industrial sealing applications, involving lower temperatures, pressures and less aggressive media. The relatively soft and conformable nature of Flexitallic 45 enables sealing to be achieved with minimum gland pressure. Typical sealing applications include hot and cold water, mild chemicals and waste water treatment.

Properties

Materials of construction: High quality soft cotton yarn impregnated with grease (break-in lubricant) and graphite finish.

Colour – Black

Typical Applications

Pumps, mixers and valves.

Temperature

Maximum: 120°C (248°F)

Minimum: -20°C (-5°F)

Pressure

Maximum: Rotating – 2.5MPa (365 psi)

Valve – 7MPa (1015 psi)

Reciprocating – 10MPa (1450 psi)

Speed

Maximum: Rotating – 5 m/s (984 fpm)

Valve – 2 m/s (394 fpm)

Reciprocating – 2 m/s (394 fpm)

pH Range

5 – 9

Standard Sizes (mm sq.)

3.2, 5.0 – 20m spools.

6.5, 8.0, 9.5, 12.5, 14.0, 16.0, 19.0, 22.0, 25.0 – 8m spools

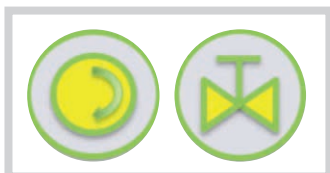

FLEXITALLIC 50

Flexitallic 50 is an X-braided compression packing, constructed from ramie yarn, heavily impregnated with PTFE.

Flexitallic 50 can be used in rotary and reciprocating applications specifically for the marine industry. It has a relatively high level of chemical resistance, extremely wear resistant with low friction properties, resistant to pressure and does not swell or degrade in water, thus providing long service life. This is an economic packing for general water and marine applications. The relatively strong yet conformable nature of Flexitallic style 50 provides high pressure sealing, that can be achieved for long periods of time. Typical sealing applications include cold and warm fresh or sea water, potable water, solutions containing solid particles, oils and solvents.

Properties

Materials of construction: High quality ramie yarn, heavily impregnated with PTFE.

Colour – Yellow/tan yarn with white impregnation.

Typical Applications

Rotary pumps and mixers, reciprocating pumps. FDA compliant.

Temperature

Maximum: 120°C (248°F)

Minimum: -40°C (-40°F)

Pressure

Maximum: Rotating – 4MPa (580 psi)

Valve – 7MPa (1015 psi)

Reciprocating – 100MPa (14500 psi)

Speed

Maximum: Rotating – 13 m/s (2559 fpm)

Valve – 2 m/s (394 fpm)

Reciprocating – 2 m/s (394 fpm)

pH Range

5 – 11

Standard Sizes (mm sq.)

3.2, 5.0 – 20m spools.

6.5, 8.0, 9.5, 12.5, 14.0, 16.0, 19.0, 22.0, 25.0 – 8m spools

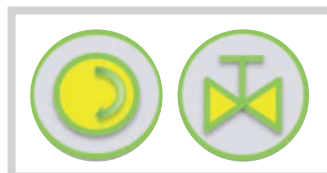



FLEXITALLIC 304

Flexitallic 304 compression packing is constructed by X-braiding high quality carbon yarn, impregnated with high performance lubricant, corrosion inhibitors and sacrificial zinc, reinforced with Inconel® wire.

Flexitallic 304 can be used in valve stems, rotary and reciprocating applications, handling most chemical media. Flexitallic 304 is particularly suitable for use in stainless steel equipment, handling high temperature and high pressure fluids, where corrosion issues may be encountered. The Inconel® wire reinforcement provides stability and aids extraction from gland housings. Typical sealing applications include use in power generation (steam), chemical and petrochemical industries.

Properties

Materials of construction: Carbon fibre yarn, pre-treated with high performance lubricants. Inconel® wire reinforcement with corrosion inhibitors and sacrificial zinc included. Graphite coating added.

Colour – Black (dull)

Typical Applications

Valve stems, rotary and reciprocating pumps.

Temperature

Maximum: 430°C (806°F)

Minimum: -50°C (-58°F)

Pressure

Maximum: Rotating – 2.5MPa (362 psi)

Valve – 20MPa (2900 psi)

Reciprocating – 10MPa (1450 psi)

Speed

Maximum: Rotating – 20 m/s (3937 fpm)

Valve – 2 m/s (394 fpm)

Reciprocating – 2 m/s (394 fpm)

pH Range

0 – 14

Standard Sizes (mm sq.)

3.2, 5.0 – 20m spools.

6.5, 8.0, 9.5, 12.5, 14.0, 16.0, 19.0, 22.0, 25.0 – 8m spools

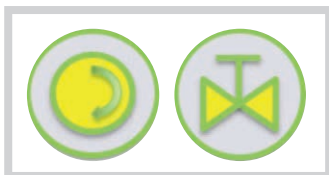

FLEXITALLIC 305

Flexitallic 305 compression packing is a high quality packing constructed by square-braiding, high purity exfoliated graphite.

Flexitallic 305 can be used in sealing pump shafts and valve stems. The soft compressible nature of exfoliated graphite assists in providing good sealing performance at relatively low loads. Flexitallic 305 possesses excellent chemical resistance and is suitable for use in applications involving a wide range of media (with the exception of strong oxidising chemicals). This packing material is particularly suitable for sealing high pressure, high temperature valves in the power generation (steam), chemical and petrochemical industries.

Properties

Materials of construction: High purity exfoliated graphite.

Colour – Black (shiny)

Typical Applications

Rotary pumps and valve stems.

Temperature

Maximum: 460°C (860°F)

Minimum: -200°C (-328°F)

Pressure

Maximum: Rotating – 2.5MPa (363 psi)

Valve – 20MPa (2900 psi)

Reciprocating – 10MPa (1450 psi)

Speed

Maximum: Rotating – 20 m/s (3937 fpm)

Valve – 2 m/s (394 fpm)

Reciprocating – 2 m/s (394 fpm)

pH Range

0 – 14

Standard Sizes (mm sq.)

3.2, 5.0 – 20m spools.

6.5, 8.0, 9.5, 12.5, 14.0, 16.0, 19.0, 22.0, 25.0 – 8m spools

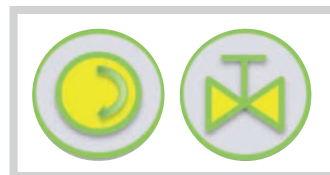



FLEXITALLIC 306

Flexitallic 306 compression packing is a high quality packing constructed by square-braiding, high purity, exfoliated graphite, reinforced with Inconel® wire.

Flexitallic 306 is a conformable, naturally lubricious braided packing, primarily designed for use in high pressure, high temperature valve stem sealing applications. The soft compressible nature of Flexitallic 306 assists in providing good sealing performance at relatively low loads, which makes the packing particularly suitable for sealing actuated valves. Flexitallic 306 possesses excellent chemical resistance and is suitable for applications involving a wide range of media (with the exception of strong oxidising chemicals). This packing material is particularly suitable for sealing high pressure, high temperature valves in the petrochemical, chemical, oil & gas industries.

Properties

Materials of construction: High purity exfoliated graphite and Inconel® wire reinforcement.

Colour – Black (shiny)

Typical Applications

Valve stems.

Temperature

Maximum: 460°C (860°F) / 650°C (1202°F) in steam

Minimum: -200°C (-328°F)

Pressure

Maximum: Rotating – 2.5MPa (363 psi)

Valve – 30MPa (4350 psi)

Reciprocating – 2.5MPa (363 psi)

Speed

Maximum: Rotating – 1 m/s (197 fpm)

Valve – 2 m/s (394 fpm)

Reciprocating – 1 m/s (197 fpm)

pH Range

0 – 14

Standard Sizes (mm sq.)

3.2, 5.0 – 20m spools.

6.5, 8.0, 9.5, 12.5, 14.0, 16.0, 19.0, 22.0, 25.0 – 8m spools



FLEXITALLIC 308 - FUGITIVE EMISSIONS

Flexitallic style 308, is a high quality Fugitive Emissions square braided packing, using high purity exfoliated graphite, over-knitted with Inconel® wire. Contains a high temperature corrosion inhibitor.

Flexitallic 308 is a conformable, strong and stable braided packing, primarily designed for use in high pressure, high temperature valve stem sealing applications, where the control of emissions is paramount. Flexitallic 308 possesses excellent chemical resistance and is suitable for use in applications involving a wide range of media (with the exception of strong oxidising chemicals). This packing material is particularly suitable for sealing high pressure, high temperature valves in oil & gas, petrochemical and general industries.

Properties

Materials of construction: High purity (>99.0%) exfoliated graphite and Inconel® wire reinforcement.

Colour – Black (shiny)

Typical Applications

Valve stems.

Approvals: TA-Luft, ISO 15848, API-622 and API 589 Fire-Safe.

Temperature

Maximum: 460°C (860°F) / 650°C (1202°F) in steam

Minimum: -200°C (-328°F)

Pressure

Maximum: Rotating – 2.5MPa (363 psi)

Valve – 45MPa (6525 psi)

Reciprocating – n/a

Speed

Maximum: Rotating – 1 m/s (197 fpm)

Valve – 2 m/s (394 fpm)

Reciprocating – n/a

pH Range

0 – 14

Standard Sizes (mm sq.)

3.2, 5.0 – 20m spools.

6.5, 8.0, 9.5, 12.5, 14.0, 16.0, 19.0, 22.0, 25.0 – 8m spools





FLEXITALLIC 310

Flexitallic 310 compression packing is constructed by X-braiding high quality carbon filament reinforced graphite tape, with a secondary reinforcement using additional strands of carbon yarn.

Flexitallic 310 can be used in valve stems, rotary and reciprocating applications handling most chemical media. Flexitallic 310 is particularly suitable for use in stainless steel equipment handling, high temperature and high pressure fluids, where corrosion issues may be encountered. The additional strands of carbon yarn reinforcement provides stability, resilience and anti-extrusion properties. This packing style does not damage or wear the shaft / spindle. Typical sealing applications include use in power generation (steam valves, boiler-feed pumps, condensate pumps etc), chemical and petrochemical industries. Suitable for most chemicals except strong oxidizing agents.

Properties

Materials of construction: Graphite tape reinforced with carbon filaments and carbon fibre yarn.

Colour – Black (shiny)

Typical Applications

Valve stems, mixers, rotary and reciprocating pumps.

Temperature

Maximum: 430°C (806°F) / 650°C (1202°F) in steam

Minimum: -50°C (-58°F)

Pressure

Maximum: Rotating – 2.5MPa (362 psi)

Valve – 45MPa (6525 psi)

Reciprocating – 10MPa (1450 psi)

Speed

Maximum: Rotating – 20 m/s (3937 fpm)

Valve – 2 m/s (394 fpm)

Reciprocating – 2 m/s (394 fpm)

pH Range

0–14

Standard Sizes (mm sq.)

3.2, 5.0 – 20m spools.

6.5, 8.0, 9.5, 12.5, 14.0, 16.0, 19.0, 22.0, 25.0 – 8m spools

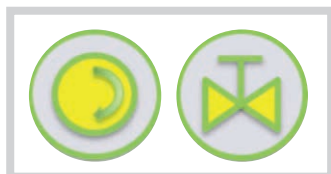

FLEXITALLIC 713L

Flexitallic 713L compression packing is constructed by X-braiding air texture, continuous filament glass yarns, impregnated with PTFE dispersion and high quality break-in lubricant.

Flexitallic 713L is primarily used in rotary and reciprocating applications, handling a wide range of chemical media, including oils, solvents, mild acids and alkalis. Sealing applications include petrochemical, chemicals, foodstuffs, pharmaceuticals, paint and brewing industries. Particularly suitable for mine de-watering pumps.

Properties

Materials of construction: Air textured glass filament yarns, impregnated with PTFE dispersion and break-in lubricant.

Colour – Off-white (light grey)

Typical Applications

Pumps, mixers and control valves.

Temperature

Maximum: 290°C (554°F)

Minimum: -85°C (-120°F)

Pressure

Maximum: Rotating – 2.5MPa (362 psi)

Valve – 14MPa (2030 psi)

Reciprocating – 10MPa (1450 psi)

Speed

Maximum: Rotating – 10 m/s (2030 fpm)

Valve – 2 m/s (394 fpm)

Reciprocating – 2 m/s (394 fpm)

pH Range

3–12

Standard Sizes (mm sq.)

3.2, 5.0 – 20m spools.

6.5, 8.0, 9.5, 12.5, 14.0, 16.0, 19.0, 22.0, 25.0 – 8m spools

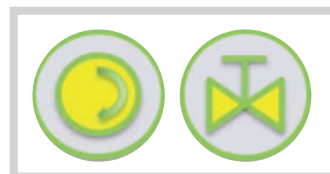



FLEXITALLIC 774

Flexitallic 774 compression packing is constructed by X-braiding glass yarn, impregnated with mineral oil and graphite.

Flexitallic 774 is primarily used in rotary pump and valve applications, handling a wide range of chemical media, including water, mild acids and alkalis, oils and general chemicals. Sealing applications include petrochemical and general industrial use. Particularly suitable for general service pumps.

Properties

Materials of construction: Continuous filament glass yarns, impregnated with mineral oil and graphite.

Colour – Black (dull)

Typical Applications

Pumps, mixers and control valves.

Temperature

Maximum: 480°C (896°F)

Minimum: -85°C (-120°F)

Pressure

Maximum: Rotating – 2.5MPa (362 psi)

Valve – 14MPa (2030 psi)

Reciprocating – 10MPa (1450 psi)

Speed

Maximum: Rotating – 10 m/s (2030 fpm)

Valve – 2 m/s (394 fpm)

Reciprocating – 2 m/s (394 fpm)

pH Range

3 – 12

Standard Sizes (mm sq.)

3.2, 5.0 – 20m spools.

6.5, 8.0, 9.5, 12.5, 14.0, 16.0, 19.0, 22.0, 25.0 – 8m spools

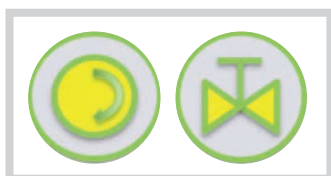

FLEXITALLIC 801

Flexitallic 801 compression packing is constructed by X-braiding graphite impregnated PTFE yarn with reinforced multi-filament aramid yarn corners.

Flexitallic 801 is primarily used in high speed rotary pump applications and for handling abrasive materials. The materials and construction provide a strong superior performance packing, that provides low friction and is thermally conductive, thus keeping the running temperatures low. The corners provide anti-extrusion and anti-wear properties at elevated operating temperatures. It is suitable for a wide range of chemical media, including water, steam, salt solutions, alkalis, organic solvents, mild acids, hydrocarbons and moderate chemical services. Most suited for rotary and plunger pumps.

Properties

Materials of construction: Graphite impregnated PTFE yarns with multifilament aramid yarns impregnated with silicone-free break-in lubricant.

Colour – Dark grey / black middle with yellow corners.

Typical Applications

Rotary and plunger pumps.

Temperature

Maximum: 280°C (536°F)

Minimum: -50°C (-58°F)

Pressure

Maximum: Rotating – 2.5MPa (363 psi)

Valve – n/a

Reciprocating – 25MPa (3625 psi)

Speed

Maximum: Rotating – 25 m/s (1970 fpm)

Valve – n/a

Reciprocating – 2 m/s (394 fpm)

pH Range

1 – 13

Standard Sizes (mm sq.)

3.2, 5.0 – 20m spools.

6.5, 8.0, 9.5, 12.5, 14.0, 16.0, 19.0, 22.0, 25.0 – 8m spools





FLEXITALLIC 802

Flexitallic 802 compression packing is constructed by X-braiding white PTFE yarn with reinforced multi-filament aramid yarn corners.

Flexitallic 802 compression packing is primarily used in high speed rotary pump applications and for handling abrasive materials. The materials and construction provide a strong, superior performance packing, that provides low friction and the corners provide anti-extrusion and anti-wear properties at elevated operating temperatures. It is suitable for fine powders, including sugar and other food stuffs. In addition, it is resistant to a wide range of chemical media, including water, steam, salt solutions, alkalis, organic solvents, mild acids, hydrocarbons and moderate chemical services. Most suited for rotary and plunger pumps, mixers and valves.

Properties

Materials of construction: White PTFE yarns with multi-filament aramid yarns, all impregnated with a silicone-free break-in lubricant.

Colour – White middle with yellow corners.

Typical Applications

Rotary and plunger pumps, mixers and valves.

Temperature

Maximum: 280°C (536°F)

Minimum: -50°C (-58°F)

Pressure

Maximum: Rotating – 2.5MPa (362 psi)

Valve – 25MPa (3625 psi)

Reciprocating – 25MPa (36250 psi)

Speed

Maximum: Rotating – 20 m/s (1576 fpm)

Valve – 2 m/s (394 fpm)

Reciprocating – 2 m/s (394 fpm)

pH Range

2 – 13

Standard Sizes (mm sq.)

3.2, 5.0 – 20m spools.

6.5, 8.0, 9.5, 12.5, 14.0, 16.0, 19.0, 22.0, 25.0 – 8m spools

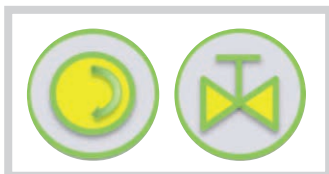

FLEXITALLIC 803

Flexitallic 803 compression packing is constructed by X-braiding acrylic yarns, impregnated with PTFE dispersion and high quality break-in lubricant.

Flexitallic 803 is primarily used in rotary pump applications, handling a wide range of chemical media including water, steam, most solvents, mild acids and moderate chemical services. Will not cause contamination or discolouration of the process media. Sealing applications include water and mild chemicals in general industrial services, suitable for contact with food and potable water.

Properties

Materials of construction: Acrylic yarns impregnated with PTFE dispersion and break-in lubricant.

Colour – Off-white.

Typical Applications

Pumps, mixers and control valves.

Approvals: WRAS / BS 6920:2000

Temperature

Maximum: 150°C (302°F)

Minimum: -50°C (-58°F)

Pressure

Maximum: Rotating – 2MPa (290 psi)

Valve – 10MPa (1450 psi)

Reciprocating – n/a

Speed

Maximum: Rotating – 12 m/s (2362] fpm)

Valve – 2 m/s (394 fpm)

Reciprocating – n/a

pH Range

2 – 12

Standard Sizes (mm sq.)

3.2, 5.0 – 20m spools.

6.5, 8.0, 9.5, 12.5, 14.0, 16.0, 19.0, 22.0, 25.0 – 8m spools

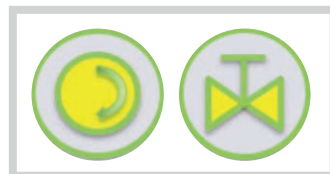



FLEXITALLIC 900

Flexitallic 900 compression packing is a high quality compression packing constructed by X-braiding PTFE yarn impregnated with graphite and a high temperature lubricant.

Flexitallic 900 can be used in rotary, reciprocating and static sealing applications, handling most chemical media. Exceptions are molten alkali metals and strong oxidizing media, such as oleum, aqua regia and fuming nitric acid. Typical sealing applications include petrochemical, chemical, brewing, paper and pulp industries.

Properties

Materials of construction: PTFE yarn impregnated with graphite and high temperature lubricant.

Colour – Black.

Typical Applications

Pumps, mixers and control valves.

Approvals: FDA Compliance.

Temperature

Maximum: 260°C (500°F)

Minimum: -85°C (-120°F)

Pressure

Maximum: Rotating – 2MPa (290 psi)

Valve – 20MPa (2900 psi)

Reciprocating – 15MPa (2174 psi)

Speed

Maximum: Rotating – 20 m/s (3940 fpm)

Valve – 2 m/s (394 fpm)

Reciprocating – 2 m/s (394 fpm)

pH Range

0 – 14

Standard Sizes (mm sq.)

3.2, 5.0 – 20m spools.

6.5, 8.0, 9.5, 12.5, 14.0, 16.0, 19.0, 22.0, 25.0 – 8m spools

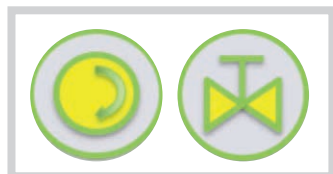

FLEXITALLIC 2001

Flexitallic 2001 is a high performance compression packing constructed by X-braiding high strength aramid yarn, treated with PTFE dispersion and a high temperature lubricant.

Flexitallic 2001 can be used in rotary, reciprocating and static sealing applications, handling a large range of chemical media. It is particularly good in sealing water, steam, organic solvents, fuels, oils and most commonly encountered acids and alkalis. Typical sealing applications include steel, chemical, paper, pulp and cement industries. Particularly recommended for pumping abrasive slurries.

Properties

Materials of construction: Aramid yarn impregnated with PTFE dispersion and high temperature silicone-free lubricant.

Colour – Yellow (straw).

Typical Applications

Pumps, mixers and isolating valves.

Temperature

Maximum: 260°C (500°F)

Minimum: -85°C (-120°F)

Pressure

Maximum: Rotating – 2MPa (290psi)

Valve – 25MPa (3635 psi)

Reciprocating – 4MPa (580 psi)

Speed

Maximum: Rotating – 15 m/s (2953 fpm)

Valve – 2 m/s (394 fpm)

Reciprocating – 2 m/s (394 fpm)

pH Range

2 – 12

Standard Sizes (mm sq.)

3.2, 5.0 – 20m spools.

6.5, 8.0, 9.5, 12.5, 14.0, 16.0, 19.0, 22.0, 25.0 – 8m spools

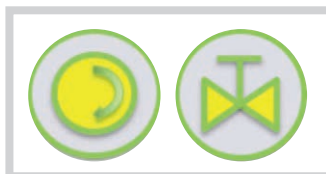

HIGH TEMPERATURE PACKINGS



FLEXITALLIC GP1, GP2, GP125

Flexitallic GP1, GP2 and GP125 compression packings, are constructed by braiding high quality continuous filament 'E' glass yarns.

Flexitallic compression packing styles GP1, GP2 and GP125 can be used in static high temperature applications handling a wide range of media. GP1, GP2 and GP125 are resistant to oils, solvents, mild acids and alkalis. These packings are recommended for static sealing applications, such as high temperature panels and inspection hatch doors that are opened occasionally.

- GP1 – Compact 'high' density flexible packing.
- GP2 – 'Medium' density flexible packing.
- GP125 – 'Low' density flexible packing.

Properties

Materials of construction: Continuous filament 'E' glass yarn.

Colour – Off-white.

Typical Applications

Static seals and caulking thermal insulation and seating for boilers, furnace joints, oven and autoclave doors, including coal and wood burning stove door seals.

Temperature

Maximum: 600°C (1112°F)

Minimum: -50°C (-58°F)

Pressure

Maximum: Static – 0.1MPa (14.5 psi)

Rotating – n/a

Reciprocating – n/a

Speed

Maximum: n/a

pH Range

5 – 11

Standard Sizes (mm) Round or Square section

3.0, 4.0, 5.0, 6.5, 8.0, 9.5, 12.5, 14.0, 16.0, 19.0, 22.0, 25.0.

Ceramic Packings CFP1 and CFP2 available on request. Please contact customerservice@flexitallic.eu

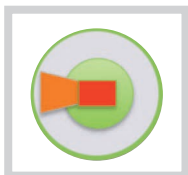

FLEXITALLIC THERMICULITE® 894

Thermiculite® 894 is a flexible gasket / compression packing, manufactured with the proprietary Flexitallic Thermiculite® critical service sealing materials.

Thermiculite® 894 is made by over-knitting strips of Thermiculite® foil with a fine (0.09mm diameter) Inconel® 600 wire and then braiding a number of those Thermiculite / Inconel® strips to produce a square section sealing material available in continuous coil form.

Thermiculite® 894 is intended for high temperature and / or aggressive media applications where a flexible gasket / packing is required. Such applications include but is not limited to oven door seals, very large diameter and / or distorted flanges such as those found in the production of ammonia based industrial fertilisers.

This material can also be used in conventional high temperature valve stem sealing systems for on-off or isolation valves. Alternatively, as the header rings either side of a conventional valve stem sealing stack it can provide an oxidation barrier for the standard graphite components.

Please contact Flexitallic's applications engineering team for technical advice.

Temperature

Maximum: 1050°C (1920°F)

pH Range

0 – 14

Standard Sizes (mm sq.)

The following square section material is available in coils:

5.0mm

6.0mm - 6.5mm

8.0mm

9.5mm - 10.0mm

12.0mm - 12.5mm

15.0mm

19.0mm

Standard coil lengths are 8m and 20m for small section sizes.

Rectangular cross-sections are possible; please ask about particular section sizes and coil length requirements.

Thermiculite®
innovative. versatile. complete.

FUGITIVE EMISSIONS MANAGEMENT

Flexitallic have a number of Fugitive Emissions products that are used for valve stem sealing, these include:

Flexitallic style **308** compression packing
Enviroflex™ **500** stem sets

CONTROL & STANDARDS

Fugitive Emission – Legislation

Various industrial and governmental bodies have established standards to limit the level of Fugitive Emissions for both new and existing equipment. Fugitive emissions are also known as Volatile Fugitive Emissions (VOC's). VOC emissions have a detrimental affect on the environment, H&S and plant efficiency.

Many site surveys have shown that leakages from valves, significantly contribute to the release of VOC's, particularly from control valve stems.

Flexitallic provide valve compression packing and valve stem sets that, when installed correctly, achieve leakage rates that are consistently less than the emission levels set by the various governing bodies.

Fugitive Emission Control

Correct selection and installation of the compression packing or valve stem sets helps to:

- Meet the required Fugitive Emissions **STANDARD**.
- Protect the **ENVIRONMENT**.
- Increase site **SAFETY**.
- Increase plant **EFFICIENCY** and reduce **DOWNTIME**.
- Improve **PROFITABILITY**.

Which Standards are Applicable

The main international and industry standards that are applicable for refineries and chemical processing plants are:

API 622, API 624, ISO 15848 (Parts 1 & 2), Clean Air Act, TA-Luft and VDI 2440.

It should be noted that these standards do not share the same permissible leakage rates, test methods, methods of measuring and units of measurement and consequently are not always directly comparable.

STANDARD	CLASS	MAXIMUM LEAKAGE RATE	COMPARISON - LEAKAGE RATE
ISO 15848 - Class A	Class A	$\leq 10^{-6}$ mg / (s x m)	
ISO 15848 - Class B	Class B	$\leq 10^{-4}$ mg / (s x m)	
ISO 15848 - Class C	Class C	$\leq 10^{-2}$ mg / (s x m)	
Shell MESC SPE 77/312	Class A	$\leq 10^{-5}$ mg / (s x m)	
Shell MESC SPE 77/312	Class B	$\leq 10^{-4}$ mg / (s x m)	
TA-Luft (VDI 2440)	<250°C	$\leq 10^{-5}$ mg / (s x m)	
TA-Luft (VDI 2440)	$\geq 250^\circ\text{C}$	$\leq 10^{-3}$ mg / (s x m)	

The above table includes the Shell MESC SPE 77/312 permissible leakage rates.

SUMMARY OF FUGITIVE EMISSIONS STANDARDS

API 622

API 622, 2nd Edition: 2008, is a valve packing (either compression packing or stem sets) performance test that considers several operating conditions such as temperature, pressure, thermal and mechanical cycling.

This standard requires the packing to be subjected to 1510 mechanical cycles and 5 thermal cycles. In addition, high temperature tests shall be performed from ambient temperature to 260°C (500°F) and pressures from atmospheric to 600 psig (0 – 41 barg). Testing with Methane, the maximum permissible leakage rate is set at 100 ppm.

API 624

API 624, 1st Edition: 2009, is a 'Type Test' for rising stem valves fitted with a Graphite Packing for Fugitive Emissions. This performance test is applied to both translational and rotational valve stem movement in valves up to 24" (600 NB) diameter and must be undertaken using the original production valves.

The API 624 test procedure submits the valve to 310 mechanical cycles and three thermal cycles up to 260°C (500°F). The maximum allowable leakage rate is 100ppm. This test also stipulates that the valve packing used must be previously tested and approved to API 622 and be suitable for normal service temperatures of -29°C to +538°C (-20°F to 1000°F).

FUGITIVE EMISSIONS MANAGEMENT

Clean Air Act

This act is applicable in the USA and defines the maximum allowable leakage levels for flange connections, valves, pumps and agitators. Leakage testing is undertaken using methane and is performed in accordance with EPA Method 21 (sniffing method).

ISO 15848

ISO 15848 is separated into two parts and describes the fugitive emissions measurement, test and qualification procedures for industrial valves. The two parts are:

- ISO 15848-1: Classification system and classification procedures for 'Type Testing of Valves'.
- ISO 15848-2: Specifies the production acceptance test of valves for the valve manufacturer.

ISO 15848 grades three tightness classes:

GRADE	MEASURED	COMMENTS LEAKAGE RATE
A (Helium only)	$\leq 10^{-6}$ mg/(s x m)	Leakage rate normally achieved with 'bellow seals' or equivalent spindle / shaft sealing system for swivel valves.
B	$\leq 10^{-4}$ mg/(s x m)	This leakage rate and test is typically obtained when using a PTFE or Elastomer based packing system.
C	$\leq 10^{-2}$ mg/(s x m)	This specified leakage rate limit is normally applicable to flexible graphite packings.

TA-Luft (VDI 2440)

Fugitive emission control legislation in Germany is specified in TA-Luft regulation to VDI 2440 for defining leakage rates, test and measuring methods.

The following maximum valve leakage rates of VOC's are defined by VDI 2440.

TEST TEMPERATURE	MAXIMUM ALLOWABLE MEASURED LEAKAGE RATE
<250°C (482°F)	$\leq 10^{-4}$ mbar x l / (s x m)
$\geq 250^\circ\text{C}$ (482°F)	$\leq 10^{-2}$ mbar x l / (s x m)

Flange connections in accordance with VDI 2200, VDI 2440 and TA-Luft

Although not directly related to compression packing and stem sets in valves, this is still relevant to the valve. In accordance with TA-Luft and VDI 2440, flange connections must comply with the maximum leakage rate of 10^{-4} mbar x l (s x m) at a test pressure of 1 bar. VDI 2200 defines the calculation, design and assembly of bolted flange connections in addition to the test procedures and references VDI 2440 with respect to the maximum permissible leakage rates. VDI 2200 also defines the criteria for the gasket 'Blow-out' safety test.

Flexitallic – Fugitive Emissions Products

Flexitallic have a number of products that are used for valve stem sealing that are independently certified or tested and in compliance with a number of the fugitive emission standards. The main products are (and not limited to):

- Flexitallic style **308** compression packing.
- Enviroflex™ **500** stem sets.

FUGITIVE EMISSION SETS



FLEXITALLIC ENVIROFLEX™ 500

Flexitallic Enviroflex™ 500 is a high performance, 'Low Emission' / 'Fugitive Emission' valve stem set.

Flexitallic Enviroflex™ 500 is supplied as a five ring set, comprising of three die-formed graphite rings and two braided (header and footer) end rings. The three central rings are die-formed using 99.85% purity exfoliated graphite. The two end rings are made from braided packing, constructed from high-purity expanded graphite, over-knitted with Inconel® wire. Available in solid ring form only (braided graphite end rings have a single split). Not recommended for use with strong oxidising agents or alkali metals.

Properties

Materials of construction: 99.85% purity nuclear grade exfoliated graphite foil and braided packing with Inconel® wire.

Colour – Dark grey / black (shiny).

Typical Applications

Isolating and control valve stem seals.

Maximum Ash Content: 0.15%.

Maximum Leachable Chlorides: 50ppm

API 607 Fire Safe. ISO 15848-1: 2006 – CO2 tests:

Less than 50ppm measured leakage.

Temperature

Maximum: 450°C (842°F) / 650°C in steam

Minimum: -200°C (-328°F)

Pressure

Maximum: Valve – 86MPa (12470 psi)

Rotating – not applicable

Speed

Maximum: Valve only – 2 m/s (394 fpm)

pH Range

0 – 14



FLEXITALLIC ENVIROFLEX™ HOT

Flexitallic Enviroflex™ HOT is a high performance, high temperature, 'Low Emission' valve stem set.

Flexitallic Enviroflex™ HOT is supplied as a six or seven ring set. Each set is comprised of three central die-formed graphite rings, using 99.85% purity exfoliated graphite; one braided graphite, over-knitted with Inconel® wire inner header ring; one inner footer Thermiculite® TR160 ring; and two braided Thermiculite® TH894 (header and footer) end rings. The TR160 inner footer ring is optional (space dependent) and the Thermiculite® TH894 braided rings provide a thermal oxidation barrier to protect the graphite rings at high temperatures. These materials are inherently Fire Safe. Available in solid ring form only (braided graphite and Thermiculite® rings have a single split). Not recommended for use with strong oxidising agents, alkali metals, hydrofluoric acid and fluorine gas.

Properties

Materials of construction: 99.85% purity nuclear grade exfoliated graphite foil and braided graphite packing with Inconel® wire; exfoliated Thermiculite® (die-formed and braided).

Colour – Dark grey / black (shiny) and golden yellow.

Typical Applications

Isolating & control valves stem seals.

Maximum Ash Content: 0.15%.

Maximum Leachable Chlorides: 50ppm

Temperature

Maximum: 650°C (1200°F) / 650°C in steam

Minimum: -200°C (-328°F)

Pressure

Maximum: Valve – 86MPa (12470 psi)

Rotating – not applicable

Speed

Maximum: Valve only – 1 m/s (197 fpm)

pH Range

0 – 14



DIE-FORMED RINGS



FLEXITALLIC GR160

Flexitallic GR160 die-formed graphite rings, are manufactured from high purity (99.85%), nuclear grade, exfoliated graphite. Shape and sizes pre-determined by the tooling.

Flexitallic GR160 rings are primarily a high performance valve packing. Also suitable for sealing rotary and reciprocating pumps. Utilising high purity grade graphite, the GR160 rings possess excellent chemical resistance and can be used across a wide range of chemical media including oils, solvents, acids and alkalis. Not recommended for use with strong oxidising agents or alkali metals.

Properties

Materials of construction: 99.85% purity nuclear grade exfoliated graphite foil. *Industrial grade 98% purity available on request.*

Colour – Dark grey / black (shiny).

Typical Applications

Isolating & control valves stem seals seat / bonnet rings, pumps, mechanical seals. Ideal for HP steam valves.

Maximum Ash Content: 0.15%.

Maximum Leachable Chlorides: 50ppm

Temperature

Maximum: 550°C (1022°F) / 650°C (1202°F) in steam / >1600°C (2912°F) in non-oxidising media

Minimum: -200°C (-328°F)

Pressure

Maximum: Rotating – 2MPa (290 psi)

Valve – 100MPa (14500 psi)

Reciprocating – 10MPa (1450 psi)

Speed

Maximum: Rotating – 15 m/s (2955 fpm)

Valve – 2 m/s (394 fpm)

Reciprocating – 2 m/s (394 fpm)

pH Range

0 – 14

Density

Standard – 1.60 g/cc

(1.35 g/cc Min. up to 1.85 g/cc Max).



FLEXITALLIC TR160

Flexitallic TR160 die-formed rings, are manufactured from exfoliated Thermiculite® foil. Shape and sizes pre-determined by the tooling.

Flexitallic TR160 rings have been primarily developed as a component part of a high performance, high temperature valve packing. It is also suitable for static sealing applications such as valve seat / bonnet seals. Thermiculite® possesses excellent chemical resistance, consequently Flexitallic TR160 rings can be used across a wide range of chemical media including oils, solvents, acids and alkalis. Especially suitable for 'Molten Salt' applications. Not a dynamic seal. Available in ring form, whole (solid) or split in halves. Not recommended for use with hydrofluoric acid and fluorine gas.

Properties

Materials of construction: Exfoliated Thermiculite® foil (standard and polymer-free TR160-PF).

Colour – Golden yellow.

Typical Applications

Isolating & control valves stem seals and static seat / bonnet rings.

Maximum Leachable Chlorides: 50ppm

Temperature

Maximum: 1000°C (1822°F)

Minimum: -200°C (-328°F)

Pressure

Maximum: Rotating – n/a

Valve – 40MPa (5800 psi)

Reciprocating – n/a

Speed

Maximum: Rotating – n/a

Control Valve – 1 m/s (197 fpm)

Reciprocating – n/a

pH Range

0 – 14

Density

Standard – 1.85 g/cc

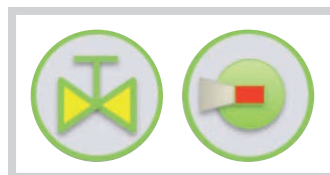

HIGH TEMPERATURE STEM SETS



FLEXITALLIC TR160 / TH894 STEM SETS

Flexitallic TR160 / TH894 Stem Sets are comprised of multiple die-formed rings and loose formed / partially blocked compression packing manufactured from Thermiculite®.

Flexitallic TR160 / TH894 Stem Sets have been developed primarily for high temperature Molten Salt Valve applications. Each set is comprised of a TH894 header and footer ring, loosely blocked to size and shape with a single scarf cut, with two to six TR160 die-formed central rings (stuffing box depth dependent). As standard, the TR160 components are supplied as solid rings, however, they can be split in half to aid installation. Thermiculite® possesses excellent thermal and chemical resistance, consequently, Flexitallic TR160 / TH894 Stem Sets are especially suitable for 'Molten Salt' applications where graphite and standard stem packing materials are both chemically and thermally degraded.

Properties

Materials of construction: Die-formed Thermiculite® foil and TH894 packing (Inconel® 600 wire reinforced Thermiculite® foil). These sets are treated with a high temperature inorganic dry lubricant.

Colour – Golden yellow / brown.

Typical Applications

High temperature Isolating and Control Valve Stem Sets.

Maximum Leachable Chlorides

50 ppm

Temperature

Maximum: 1000°C (1822°F)

Minimum: -200°C (-328°F)

Pressure

Maximum: Valve – 40MPa (5800 psi)

Rotating or Reciprocating Pumps – n/a

Speed

Maximum: Control Valve – 1 m/s (197 fpm)

Rotating or Reciprocating Pumps – n/a

pH Range

0 – 14

Density

Standard TR160 rings – 1.85 g/cc

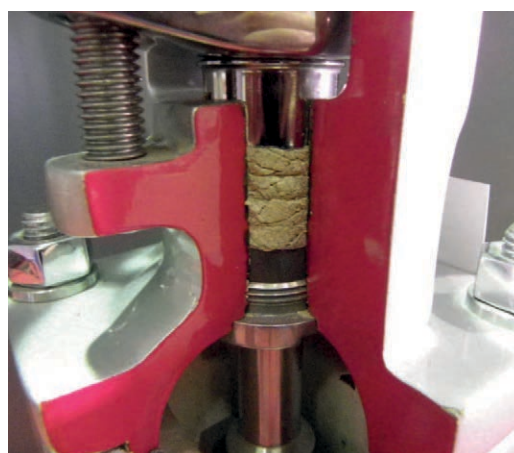

Flexitallic stem sets for High Temperature applications are designed for each application on its own merits. TR160 / TH894 stem sets have proven to be successful where traditional packings fail due to either chemical and / or thermal degradation. Molten Salt applications are where these stem sets surpass all other stem sealing products.

These Thermiculite® based products are inherently fire safe and are suitable for a vast range of chemicals at temperatures above 350°C.

TR160 and TH894 rings are not designed for dynamic applications and they are not recommended for rotary or reciprocating equipment.

For Molten Salt and other high temperature applications, Flexitallic offer other sealing products such as solid metal RTJ's, Spiral Wound Gaskets, Flexpro™ Kammprofile and Change™ gaskets.

Combination Sets

TH894 and / or TR160 rings are often used to provide a thermal barrier to protect Graphite rings from oxidation.

We recommend that any high temperature, critical service or molten salt type enquiry should be directed through Flexitallic Applications Engineering team.



VALVE BONNET / COVER SEALS



GRM160 AND TRM160 RINGS

GRM160 and TRM160 valve bonnet / cover seals are supplied as die-formed rings similar to the GR160 and TR160 rings, however, they are constructed with an integral or loose metal cap.

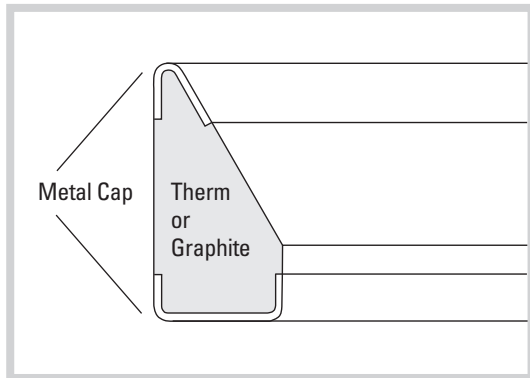

These bonnet / cover seals provide high performance sealing integrity, especially in heavy duty valves or high pressure feed water pre-heaters. They maintain elastic properties when subject to thermal cycling and high seating stresses.

The metal caps provide anti-extrusion protection in applications where radial clearances exceed 0.25mm.

GRM160 Rings – Die-Formed Graphite with metal caps

Temperature

Maximum: 550°C (1022°F) most media and air

Minimum: -200°C (-328°F) most media and air

Steam: 700°C (1292°F)

Inert Gas: 1000°C (1832°F) Metal dependent

Pressure

Up to 100MPa

pH Range

1 – 14

TRM160 Rings – Die-Formed Thermicultie with metal caps

Temperature

Maximum: 1000°C (1832°F) most media and air

Minimum: Check with Applications Engineering

Pressure

Up to 100MPa

pH Range

1 – 14

We recommend that any enquiry for these type of seal rings should be directed through Flexitallic Applications team.

GRAPHITE TAPE

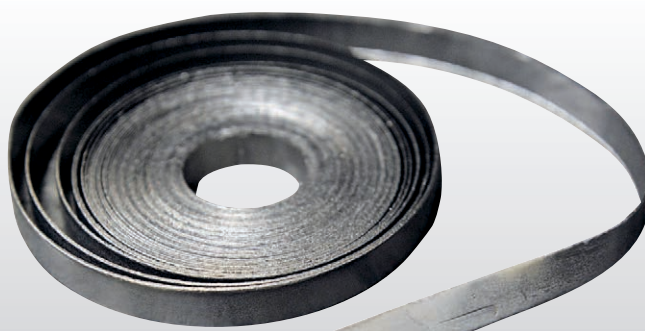

XPS RANGE OF GRAPHITE TAPE

XPS range of graphite tape is manufactured from high purity graphite. Styles 200, 400, 600 and 700 are plain tape, whilst styles 210, 410, 610 and 710 are corrugated tapes. Styles 200 and 210 are Oxidation inhibited graphite grades and styles 700 and 710 are Nuclear grades of graphite.

The XPS range of high performance flexible graphite tapes, designed for on-site sealing of pump shafts and valve stems. The product has been engineered to compress in-situ, under moderately low bolt loads, into a packing ring conforming to the stuffing box cavity, resulting in exceptionally high levels of sealing performance. The XPS range of graphite tape is particularly recommended for use with stainless steel valve stems and pump shafts. Like all high purity graphite sealing products, it possesses outstanding chemical resistance and can be used to seal a wide range of chemical media.

Operating Capabilities / Parameters

Media pH Range: 0 to 14*

Temperature

Temperature (continuous operation): -200°C to +400°C

Temperature in inert or reducing media: -200°C to +1000°C

Maximum temperature in steam: 650°C

Pressure

Maximum pressure (valves): 18MPa (180 bar)

Maximum pressure (pumps): 2MPa (20 bar)

Speed

Maximum shaft speed: 20 m/s

Availability

Tape length: 10m std. to 50m

Tape width: 10mm to 50mm

**Not recommended for use with strong oxidising agents or alkali metals.*

PROPERTIES	XPS PRODUCT NUMBER			
	200 & 210	400 & 410	600 & 610	700 & 710
Thickness (before corrugating)	0.50mm	0.50mm	0.50mm	0.50mm
Density	1.0g/cc	1.0g/cc	1.0g/cc	1.0g/cc
Carbon Content	≥98.0%wt.	≥99.0%wt.	≥98.0%wt.	≥99.85%wt.
Ash Content	≤2.0%wt.	≤1.0%wt.	≤2.0%wt.	≤0.15%wt.
Total Sulphur Content	<500ppm	<500ppm	<300ppm	<500ppm
Total Chloride Content	≤50ppm	≤10ppm	≤25ppm	≤50ppm
Total Fluoride Content	≤10ppm	≤10ppm	≤10ppm	≤50ppm

CHEMICAL COMPATIBILITY CHART

Y = Suitable for application
N = Not Suitable
C = Application dependent

MEDIA	ACRYLIC	ARAMID	GLASS	GRAPHITE	GRAPHITE / PTFE	PTFE	VEGETABLE / NATURAL
	A	B	C	D	E	F	G
Acetic Acid Glacial	N	N	N	Y	Y	Y	N
Acetone	Y	Y	Y	Y	Y	Y	N
Acetylene	Y	Y	Y	Y	Y	Y	Y
Acrylonitrile	C	Y	N	Y	Y	Y	N
Air	Y	Y	Y	Y	Y	Y	Y
Alkaline Lye	N	C	Y	Y	Y	Y	N
Aluminium Chloride	Y	C	N	Y	Y	Y	N
Ammonia Gas	Y	Y	Y	Y	Y	Y	C
Ammonia	Y	Y	Y	Y	Y	Y	N
Amyl Acetate	Y	Y	Y	Y	Y	Y	Y
Amyl Alcohol	Y	Y	Y	Y	Y	Y	Y
Aniline	C	Y	Y	Y	Y	Y	N
Aqua Regia	C	N	N	N	N	Y	N
Aviation Fuel	Y	Y	Y	Y	Y	Y	Y
Beer	Y	Y	Y	Y	Y	Y	Y
Benzene	Y	Y	Y	Y	Y	Y	C
Benzoyl Chloride	N	Y	Y	Y	Y	Y	N
Biphenyl	N	Y	Y	Y	Y	Y	N
Blast Furnace Gas	N	Y	Y	Y	Y	Y	N
Bleaching (solution)	Y	Y	C	Y	Y	Y	C
Boiler Feed Water	Y	Y	Y	Y	Y	Y	Y
Brine	Y	Y	Y	Y	Y	Y	Y
Bromine	N	N	N	N	N	Y	N
n-Butyl Acetate	Y	Y	Y	Y	Y	Y	Y
Calcium Chlorate	N	C	Y	Y	Y	Y	N
Caprolactam	Y	Y	Y	Y	Y	Y	N
Carbolic Acid	N	Y	Y	Y	Y	Y	N
Carbon Dioxide	Y	Y	Y	Y	Y	Y	Y
Carbon Disulphide	N	N	Y	Y	Y	Y	N
Carbon Monoxide	Y	Y	Y	Y	Y	Y	Y
Carbon Tetrachloride	Y	Y	Y	Y	Y	Y	N
Chile Saltpetre	Y	Y	Y	Y	Y	Y	Y
Chlorine – Dry	Y	N	Y	Y	Y	Y	N
Chlorine – Wet	N	N	Y	Y	Y	Y	N
Chlorinated Hydrocarbons	Y	Y	Y	Y	Y	Y	C
Chloroacetic Acid	N	C	N	Y	Y	Y	N
Chlorobenzene	Y	Y	Y	Y	Y	Y	N
Chromic Acid	N	N	N	C	C	Y	N
Copper Sulphate	Y	Y	Y	Y	Y	Y	Y
Creosote	N	Y	Y	Y	Y	Y	N

If a chemical is not listed, please contact Applications Engineering on +44 (0)1274 851273 for clarification.

CHEMICAL COMPATIBILITY CHART

Y = Suitable for application
N = Not Suitable
C = Application dependent

MEDIA	ACRYLIC	ARAMID	GLASS	GRAPHITE	GRAPHITE / PTFE	PTFE	VEGETABLE / NATURAL
	A	B	C	D	E	F	G
Cresol	N	Y	Y	Y	Y	Y	N
Crude Oil	Y	Y	Y	Y	Y	Y	C
Cyclohexanol	Y	Y	Y	Y	Y	Y	Y
1,4 Dichlorobenzene	C	Y	Y	Y	Y	Y	N
Diesel Oil	Y	Y	Y	Y	Y	Y	C
Dowtherm	N	Y	Y	Y	Y	Y	N
Dye Liqueur	Y	C	N	Y	Y	Y	N
Ethyl Acetate	Y	Y	Y	Y	Y	Y	N
Ethyl Alcohol	Y	Y	Y	Y	Y	Y	Y
Ethyl Ether	Y	Y	Y	Y	Y	Y	Y
Ethylene	Y	Y	Y	Y	Y	Y	Y
Ethylene Chloride	Y	Y	Y	Y	Y	Y	N
Ethylene Glycol	Y	Y	Y	Y	Y	Y	Y
Ethylene Oxide	C	Y	Y	Y	Y	Y	N
Fatty Acids	Y	Y	Y	Y	Y	Y	Y
Ferric Chloride	Y	Y	Y	Y	Y	Y	C
Fluorine	N	N	N	C	N	N	N
Fluorosilic Acid	N	Y	N	Y	Y	Y	N
Formaldehyde	C	Y	Y	Y	Y	Y	C
Formic Acid	N	C	N	Y	Y	Y	N
Gas Oil	Y	Y	Y	Y	Y	Y	C
Gasoline	Y	Y	Y	Y	Y	Y	Y
Glucose	Y	Y	Y	Y	Y	Y	Y
Heating Oil	Y	Y	Y	Y	Y	Y	Y
Hydraulic Oil (Ester)	Y	Y	Y	Y	Y	Y	C
Hydraulic Oil (Glycol)	Y	Y	Y	Y	Y	Y	Y
Hydraulic Oil (Mineral)	Y	Y	Y	Y	Y	Y	Y
Hydrazine	C	Y	Y	Y	Y	Y	N
Hydrocarbons (Aromatic)	Y	Y	Y	Y	Y	Y	N
Hydrocarbons (Aliphatic S)	Y	Y	Y	Y	Y	Y	C
Hydrocarbons (Aliphatic U)	Y	Y	Y	Y	Y	Y	C
Hydrochloric Acid (37%)	N	N	Y	Y	Y	Y	N
Hydrofluoric Acid	N	N	N	Y	Y	Y	N
Hydrogen	Y	Y	Y	Y	Y	Y	Y
Hydrogen Chloride	C	N	Y	Y	Y	Y	N
Hydrogen Fluoride	N	N	N	Y	Y	Y	N
Hydrogen Peroxide	N	N	Y	C	Y	Y	N
Hydrogen Sulphide	C	N	Y	Y	Y	Y	N
Isopropyl Acetate	Y	Y	Y	Y	Y	Y	Y
Isopropyl Alcohol	Y	Y	Y	Y	Y	Y	Y

If a chemical is not listed, please contact Applications Engineering on +44 (0)1274 851273 for clarification.

CHEMICAL COMPATIBILITY CHART

Y = Suitable for application
N = Not Suitable
C = Application dependent

MEDIA	ACRYLIC	ARAMID	GLASS	GRAPHITE	GRAPHITE / PTFE	PTFE	VEGETABLE / NATURAL
	A	B	C	D	E	F	G
Kerosene	Y	Y	Y	Y	Y	Y	Y
Lime (Quick)	Y	Y	Y	Y	Y	Y	N
Lubrication Oil	Y	Y	Y	Y	Y	Y	C
Machine Oil	Y	Y	Y	Y	Y	Y	C
Magnesium Sulphate	Y	Y	Y	Y	Y	Y	Y
Malic Acid	Y	Y	Y	Y	Y	Y	C
Methane	Y	Y	Y	Y	Y	Y	Y
Methyl Acrylate	N	Y	Y	Y	Y	Y	N
Methyl Alcohol	Y	Y	Y	Y	Y	Y	Y
Methyl Isobutyl Ketone	Y	Y	Y	Y	Y	Y	C
Methyl Methacrylate	N	Y	Y	Y	Y	Y	C
Methylene Chloride	Y	N	Y	Y	Y	Y	N
Mineral Oil	Y	Y	Y	Y	Y	Y	C
Mobiltherm	N	Y	Y	Y	Y	Y	N
Molten Salts	N	N	N	N	N	N	N
Naphthalene	C	Y	Y	Y	Y	Y	C
Natural Gas	Y	Y	Y	Y	Y	Y	Y
Nitric Acid (50%)	N	N	N	N	N	Y	N
Nitric Acid (95%)	N	N	N	N	Y	Y	N
Nitrogen	Y	Y	Y	Y	Y	Y	Y
Oleum	N	N	N	N	N	Y	N
Oxygen	N	Y	Y	Y	Y	Y	N
Paraffin	Y	Y	Y	Y	Y	Y	Y
Pentachlorophenol	N	N	C	Y	Y	Y	N
Perchloric Acid	N	N	N	N	N	Y	N
Petrol	Y	Y	Y	Y	Y	Y	Y
Phenol	N	N	C	Y	Y	Y	Y
Phosgene	N	Y	Y	Y	Y	Y	N
Phosphoric Acid (Conc.)	N	N	N	Y	Y	Y	N
Phosphoric Acid (Dil.)	C	C	C	Y	Y	Y	N
Phosphorous	N	N	Y	C	Y	Y	N
Phthalic Anhydride	C	Y	Y	Y	Y	Y	N
Potassium Hydroxide	C	C	N	Y	Y	Y	N
Potassium Nitrate	Y	Y	Y	Y	Y	Y	Y
Potassium Permanganate	Y	C	Y	Y	Y	Y	N
Producer Gas	Y	Y	Y	Y	Y	Y	Y
Pyridine	N	Y	Y	Y	Y	Y	N
Rape Seed Oil	Y	Y	Y	Y	Y	Y	Y
Silicone Oil	Y	Y	Y	Y	Y	Y	Y
Soda Ash	C	Y	N	Y	Y	Y	Y

If a chemical is not listed, please contact Applications Engineering on +44 (0)1274 851273 for clarification.

CHEMICAL COMPATIBILITY CHART

Y = Suitable for application
N = Not Suitable
C = Application dependent

MEDIA	ACRYLIC	ARAMID	GLASS	GRAPHITE	GRAPHITE / PTFE	PTFE	VEGETABLE / NATURAL
	A	B	C	D	E	F	G
Sodium Bicarbonate	Y	Y	Y	Y	Y	Y	Y
Sodium Carbonate	Y	Y	N	Y	Y	Y	Y
Sodium Cyanide	Y	Y	Y	Y	Y	Y	Y
Sodium Hydroxide (90%)	N	N	N	Y	Y	Y	N
Sodium Hydroxide (Dil.)	Y	C	C	Y	Y	Y	N
Sodium Hypochlorite	C	Y	C	Y	Y	Y	C
Sodium Nitrate	Y	Y	Y	Y	Y	Y	Y
Starch	Y	Y	Y	Y	Y	Y	Y
Steam	Y	C	C	Y	Y	Y	N
Steam Condensate	Y	Y	Y	Y	Y	Y	Y
Styrene	Y	Y	Y	Y	Y	Y	N
Sulphur	C	Y	Y	Y	Y	Y	C
Sulphur Dioxide	C	N	Y	Y	Y	Y	C
Sulphur Trioxide	N	N	N	N	N	Y	N
Sulphuric Acid (Conc.)	N	N	N	C	C	Y	N
Sulphuric Acid (Fuming)	N	N	N	N	N	Y	N
Tar	N	Y	Y	Y	Y	Y	N
Toluene	Y	Y	Y	Y	Y	Y	N
Towns Gas	Y	Y	Y	Y	Y	Y	Y
Transformer Oil	Y	Y	Y	Y	Y	Y	C
Tributyl Phosphate	Y	Y	Y	Y	Y	Y	Y
Triethanolamine	Y	Y	Y	Y	Y	Y	Y
Turpentine	Y	Y	Y	Y	Y	Y	Y
Urea	Y	Y	Y	Y	Y	Y	Y
Vegetable Oil	Y	Y	Y	Y	Y	Y	Y
Vinyl Acetate	Y	Y	Y	Y	Y	Y	C
Vinyl Chloride	Y	Y	Y	Y	Y	Y	C
Water	Y	Y	Y	Y	Y	Y	Y
Water Condensate	Y	Y	Y	Y	Y	Y	Y
Water Distilled	Y	Y	Y	Y	Y	Y	N
Whisky	Y	Y	Y	Y	Y	Y	Y
Wine	Y	Y	Y	Y	Y	Y	Y
White Spirit	Y	Y	Y	Y	Y	Y	Y
Xylene	Y	Y	Y	Y	Y	Y	Y

If a chemical is not listed, please contact Applications Engineering on +44 (0)1274 851273 for clarification.

COMPRESSION PACKING: MATERIALS & CONSTRUCTION

GENERAL

Braided compression packings are designed to provide a seal in either static or dynamic applications. Static applications can include installing a packing ring or multiple rings in-between two flanges. Dynamic applications will be to provide a seal between a static housing of a pump or valve (stuffing box / gland housing) and the moving pump shaft or valve spindle.

In certain applications involving pump packings, controlled leakage is required to provide lubrication and heat dissipation. Under steady state conditions designs of this type are intended to permit controlled leakage.

The seal is effected by inserting the appropriate number of braided compression packing rings into the stuffing box / gland housing and around the shaft / spindle. Once in position the packing rings are compressed by the gland follower.

The act of compressing the packing system results in radial movement of the individual packing / die-formed rings, effecting a seal between the shaft / spindle and stuffing box housing. In addition, the applied compressive force closes the internal structure of the packing ring material and prevents leakage through the body of the packing system

The ideal seal must be soft and conformable to correctly fill the void but resilient enough to withstand the operating pressures, resist extrusion and accommodate shaft movement. In addition, it is critical that the materials of construction are chemically compatible with media and suitable for the operating temperatures.

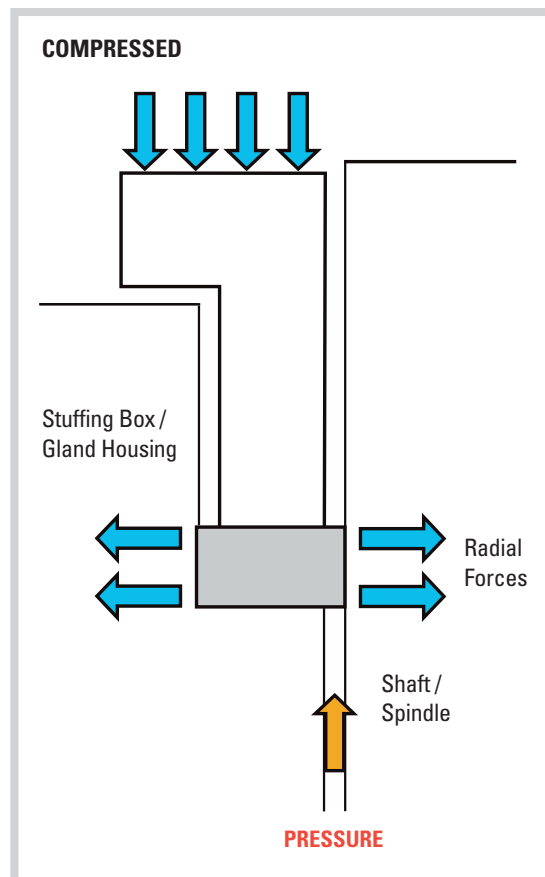
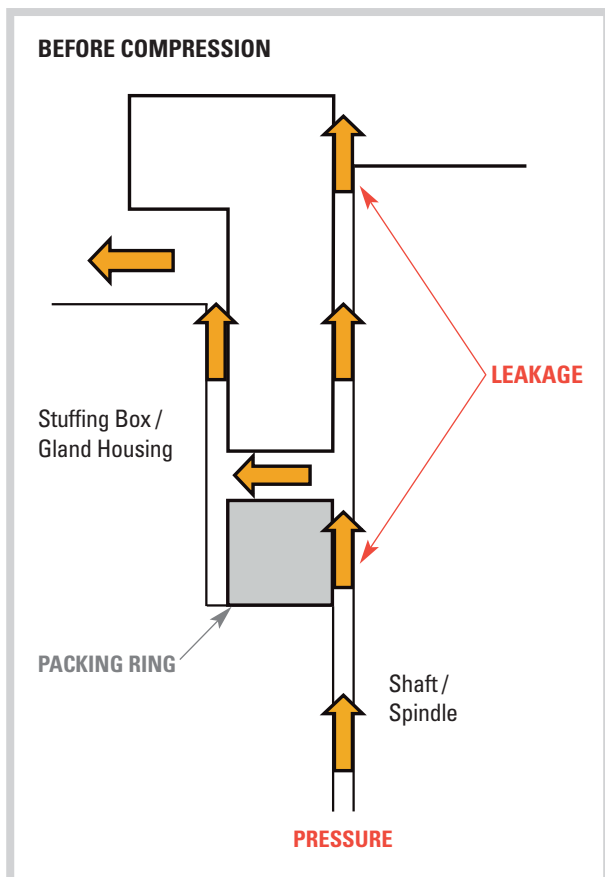

COMPRESSION PACKING: MATERIALS & CONSTRUCTION

MATERIALS

Flexitallic offer a range of compression packings to meet a large range of general and specialist applications and media. To provide high quality products the selection and use of high quality yarns, foils and lubricants in the production process is essential.

CONSTRUCTION

Compression packings are produced by a number of braiding methods which will produce products that have different mechanical properties such as stiffness and density. The most common types of braided packing construction are:

X-Braiding (Flexitallic standard construction)

Also known as '*Cross-Plait*', '*Lattice Braid*', '*Cross-Locked*' and '*Inter-Braid*'. This construction has a relatively dense structure but retains flexibility which can vary due to the material selected (acrylic is soft and aramid stiff). Each strand of yarn passes diagonally through the body of the packing at a 45° angle criss-crossing each other such that each strand is strongly locked by other strands to form a solid and stable structure.

X-Braided packings are suitable for valves, expansion joints (must be located in grooves), agitators, tongue and groove flange assemblies, centrifugal and reciprocating pumps.

Square-Braiding (Flexitallic standard construction)

This construction style is also known as '*Solid-Plait*'. Strands of material pass over and under other strands running in the same direction. The resulting square braid is relatively soft but resilient and has a relatively loose structure which allows for high quantities of lubricants to be added / impregnated.

This style of construction is ideal for high speed low pressure rotary applications.

Braid-Over-Braid (Not used in the Flexitallic standard product range)

This style is also referred to as '*Seam-Plait*', '*Braid-Over-Core*' or '*Round-Braid*'. This style of construction is achieved by braiding one or more jackets of yarn or ribbon (material dependent) over a core, which may be extruded, twisted, wrapped or knitted from either the same material or an alternative material. This type of construction provides a wide range of densities and cross-sectional shapes and sizes.

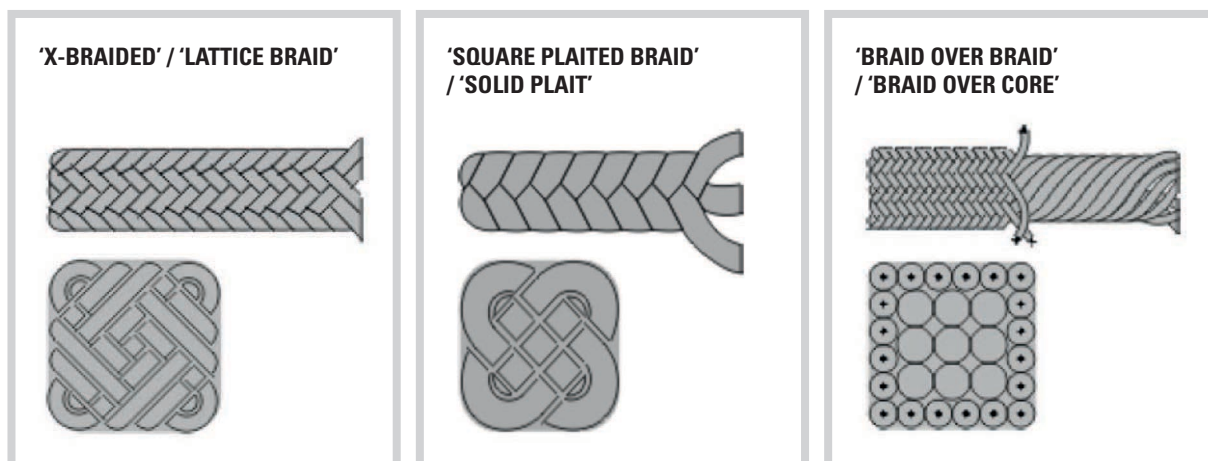

PRODUCT SELECTION: VALVE STEM PACKING



MATERIAL SELECTION

To ensure the appropriate packing or stem set is selected, as a minimum, the following parameters must be determined:

Application	Type of equipment and position (i.e. pump, valve stem etc.)
Media	Liquid or gas being sealed (Note: Flush / barrier / cleaning media also required if used)
Pressure	Internal pressure (maximum operating and test)
Temperature	Internal temperature (maximum operating – including possible upset conditions)
Speed	Shaft surface speed
Size	Cross-Section of packing

For both valve stem sets and pump gland packings other criteria must be taken into account. The following sections will detail these criteria.

When using the 'Chemical Compatibility' table, if the media being sealed is not listed, please check with Flexitallic Applications Engineering Department.

VALVE STEM PACKING

VALVE CONDITION

To ensure successful sealing is achieved, it is also essential that the equipment is in good condition. Flexitallic and leading valve manufacturers recommend the following:

Stem / Spindle Surface Finish:

Rz <1.6µm Ra 0.2µm

Longitudinal scoring to be avoided if possible. If present, to be no greater than 0.25mm deep and must not exceed a 'depth to width ratio' of 1.0.

Stuffing Box Bore / Bottom:

Rz <3.2µm Ra 0.8µm (max 1.6µm)

Stem / Spindle Runout:

Stem Diameter	Maximum TIR
≤ 38.1mm (1.500")	0.25mm (0.010")
38.2mm to 76.2mm (1.501" to 3.000")	0.50mm (0.020")
≥76.2mm (3.001")	0.75mm (0.030")

VALVE STEM PACKING

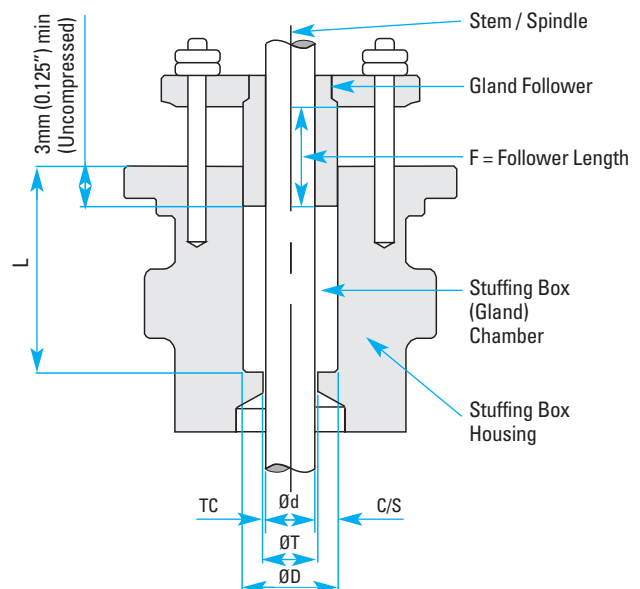

Terminology

Ød	Stem / Spindle diameter
ØD	Stuffing Box bore
ØT	Throat diameter (diameter of hole at the bottom of the stuffing box)
C/S	Cross-section = $(\text{ØD} - \text{Ød})/2$
T/C	Throat Clearance = $(\text{ØT} - \text{Ød})/2$
L	Depth of stuffing box
F	Follower length

Throat Clearance (T/C):

Radial clearance not to exceed $0.02 \times \text{C/S}$ (packing cross-section) – Min. 0.1mm – Max. 0.5mm. **Note:** For die-formed rings, the Maximum T/C shall not exceed 0.2mm.

Please complete and return the *Valve Application Form* within this brochure.

PRODUCT SELECTION: PUMP GLAND PACKING

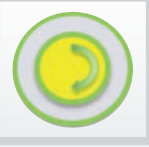

PUMP GLAND PACKING

PUMP CONDITION

To ensure successful sealing is achieved, it is also essential that the equipment is in good condition. Flexitallic and leading pump manufacturers recommend the following:

Shaft Surface Finish:

Rz <1.6µm Ra 0.2µm

Longitudinal scoring to be avoided if possible. If present, to be no greater than 0.25mm deep and must not exceed a 'depth to width ratio' of 1.0.

Stuffing Box Bore / Bottom:

Rz <3.2µm Ra 0.8µm (max 1.6µm)

Shaft Runout:

Total indicated runout (TIR) not to exceed 0.13mm (0.005")

Throat Clearance (T/C):

Radial clearance not to exceed $0.02 \times C/S$
(packing cross-section) – Min. 0.1mm – Max. 0.5mm

Note: For die-formed rings, the Maximum T/C shall not exceed 0.2mm.

Please complete and return the *Pump Application Form* within this brochure.

PUMP GLAND PACKING

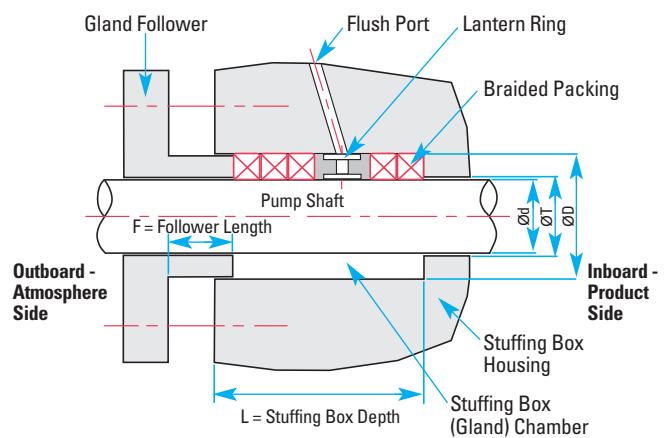

Terminology

- Ød** Stem / Spindle diameter
- ØD** Stuffing Box bore
- ØT** Throat diameter (diameter of hole at the bottom of the stuffing box)
- C/S** Cross-section = $(\text{ØD} - \text{Ød})/2$
- T/C** Throat Clearance = $(\text{ØT} - \text{Ød})/2$
- L** Depth of stuffing box
- F** Follower length

VALVE APPLICATION DATA FORM



YOUR DETAILS

CONTACT:	DATE:
COMPANY:	TEL. NO.:
ADDRESS:	FAX. NO.:
	E-MAIL:

1. EQUIPMENT

TAG NO.	Operational Type:
Isolating / Control Manufacturer:	Valve Type:

2. MEDIUM (Material Compatibility)

Media:	pH:
Concentration:	Liquid / Gas
Entrained Abrasives / Abrasive Product:	
Flush: Steam / Water / Product / Other:	
Approval Required: WRAS / FDA / TA Luft / API 622 / Other:	

3. OPERATING CONDITIONS

Temperature – Min.:	Max.:	Cont. Operating:
Temperature at Stuffing Box:		
Thermal Cycling:		Vibration:
Pressure – Min.:	Max.:	Cont. Operating:
Hydrostatic Pressure Test:	Spindle Movement: Rotational / Translational / Rising Stem	
Spindle Speed:	Spindle Stroke Length (recip):	
Maximum Spindle Run-Out (TIR):	System Cycles:	

4. CURRENT PACKING INSTALLED

5. SPINDLE & STUFFING BOX CONDITION (i.e. surface finish, score marks etc)

Spindle / Stem: _____
 Stuffing Box Bore: _____

6. STUFFING BOX DETAILS

Stuffing Box Bore 'D' =	Spindle Diameter 'd' =
Stuffing Box Depth 'L' =	Throat Diameter 'T' =
No. of Gland Bolts =	Size of Gland Bolts =
Follower Length 'F' =	

7. OTHER DETAILS (i.e. life span of current packing / failure mode etc)

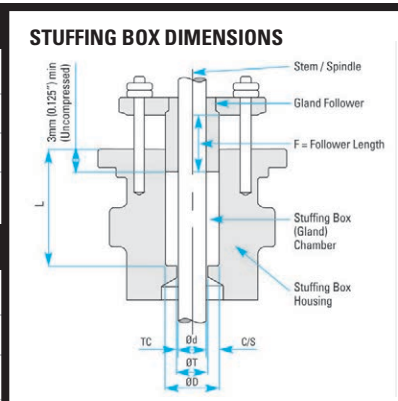

Please return form to Applications Engineering: Cleck_Technical@flexitallic.eu



PUMP APPLICATION DATA FORM



YOUR DETAILS

CONTACT:	DATE:
COMPANY:	TEL. NO.:
ADDRESS:	FAX. NO.:
	E-MAIL:

1. EQUIPMENT

TAG NO.	Pump Type:
Centrifugal / Reciprocating Type:	Other:

2. MEDIUM (Material Compatibility)

Media:	pH:
Concentration:	Liquid / Gas
Entrained Abrasives / Abrasive Product:	
Flush: Steam / Water / Product / Other:	
Approval Required: WRAS / FDA / ATEX / Other:	

3. OPERATING CONDITIONS

Temperature – Min.:	Max.:	Cont. Operating:
Temperature at Stuffing Box:		
Thermal Cycling:	Vibration:	
Pressure - Min.:	Max.:	Cont. Operating:
Hydrostatic Pressure Test:		
Shaft Speed:	Shaft Stroke Length (recip):	
Maximum Shaft Run-Out (TIR):	System Cycles:	

4. CURRENT PACKING INSTALLED

5. SHAFT & STUFFING BOX CONDITION (i.e. surface finish, score marks etc)

Shaft / Shaft Sleeve:
Stuffing Box Bore:

6. STUFFING BOX DETAILS

Stuffing Box Bore 'D' =	Shaft Diameter (d) =
Stuffing Box Depth 'L' =	Throat Diameter 'T' =
No. of Gland Bolts =	Size of Gland Bolts =
Lantern Ring Present:	Follower Length 'F' =

7. OTHER DETAILS (i.e. life span of current packing / failure mode etc)

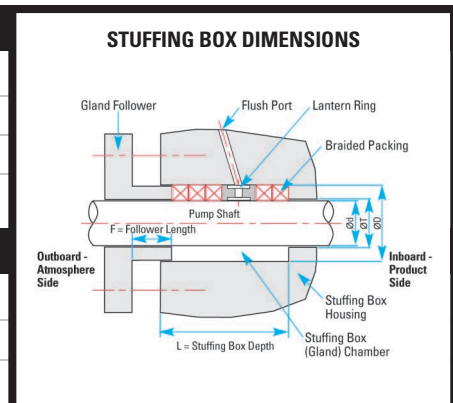

Please return form to Applications Engineering: Cleck_Technical@flexitallic.eu



VALVE STEM SETS: INSTALLATION GUIDELINES



STAGE 1 – Removal of Existing Packing Set

Remove the old packing using appropriate tools eg. packing extractors. Care should be taken not to damage the valve stem (spindle) or the bore of the stuffing box.

STAGE 2 – Inspection of Equipment

Upon removal of all traces of packing and spacers etc., carefully inspect the valve stem and the internal bore of the stuffing box. Excessively worn, pitted or scored stems should be replaced. The minimum recommended surface finish is 0.8 µm Ra (32 micro inches) for valve stems and 3.2 µm Ra (125 micro inches) for the bore and bottom of the stuffing box.

STAGE 3 – Sizing

Measure and record the stuffing box bore (internal diameter), depth and the I.D. of the stuffing box bottom (required to determine the throat clearance). The diameter of the stem and the length of any spacers should also be measured and recorded. These dimensions should be advised at time of ordering. If bushing or spacer is required, the height determined should allow a compression of up to 30% of the total uncompressed height of the selected Flexitallic Valve Stem Set. Ensure the gland follower can travel the distance required to compress the complete packing set after being lightly pressed into position.

STAGE 4 – Inspection of the Valve Stem Set

Before installation, carefully remove the valve stem set from the packaging and check that the individual components are intact and free from damage. Ensure the diameters of the stem set match those ordered with minimal diametrical clearances to allow insertion of the rings.

STAGE 5 – Installation of New Stem Set

The selected Flexitallic Valve Stem packing system is usually comprised of a number of rings ranging from three to seven sealing components (application and stuffing box height dependent). The supplied stem sets may consist of split or solid rings, or a combination of both.

Note: Care should be taken when sliding each ring over the stem / spindle and inserting into the stuffing box housing. When appropriate, ensure the rings are inserted in the correct order i.e. the footer ring inserted first and the header ring inserted last.

Ensure the footer ring is seated flat on the bottom of the stuffing box housing then compress using a tamping tool or suitable spacer ring. Depending upon style of stem set, if using plain die-formed rings, insert two at a time and compress in stages until the final header ring is installed.

After inserting the header (final) ring, using an appropriate bolt lubricant finger tighten the gland follower nuts – **first stage tightening**.

Tighten the gland follower nuts and apply an even load that is sufficient to compress the packing set to approximately 17% to 20% of the original compressed stack height of the rings – **second stage tightening**.

Actuate / operate the valve stem a minimum of 5 times, after each actuation / operation, retighten the gland follower nuts to achieve a final compression of 22% to 25% (dependent upon number and type of rings used) of the original uncompressed stack height – **third stage tightening**.

When applying a pre-determined torque value to the gland follower nuts, the torque should be applied evenly and in three stages of 30%, 60% and 100% torque. Actuate / operate the valve stem a minimum of 5 times, after each actuation / operation re-tighten the gland follower nuts to the pre-determined torque value.

Pre-Compression of Valve Packing – General Guide

Valve packings should have a minimum compression of 5 MPa. Ideally, valve packings should be compressed with a gland pressure of 2 to 4 times the media pressure.

Note: These instructions are guidelines only. Site health and safety protocols and site procedures should be followed at all times.

PUMP GLAND PACKING: INSTALLATION GUIDELINES



STAGE 1 – Removal of Existing Packing Set

Remove the old packing using appropriate tools e.g. packing extractors. Care should be taken not to damage the shaft or sleeve. Note the number of packing rings used to pack the pump. The same number of rings should be used to re-pack the pump.

STAGE 2 – Inspection of Equipment

Upon removal of all traces of packing, including any lantern rings, spacers etc. carefully inspect the pump shaft and the bore of the stuffing box. Excessively worn, pitted or scored shafts should be replaced or re-sleeved.

STAGE 3 – Sizing

Measure and note the stuffing box i.d. and pump shaft o.d. The correct packing cross section is calculated by subtracting the shaft o.d. from the stuffing box bore and dividing by two.

STAGE 4 – Cutting of Packing into Rings

All packing should be installed as individual rings. Rings should be butt or scarf cut on a mandrel with the same o.d. as the pump shaft. If using the shaft as a mandrel to size and cut the rings care is required to ensure the shaft surface is not damaged by the cutting blade (Flexitallic do not recommend this). Care should be taken not to stretch the packing while cutting as this may lead to premature leakage.

Dimensioned cutting boards are also useful aids to prepare cut lengths with a butt or scarf cut to the approximate length, when cutting in isolation to the pump shaft or mandrel.

STAGE 5 – Installation of New Stem Set

Prior to installation ensure any packing spacers have been replaced. Carefully install one ring at a time ensuring all cut end surfaces are closely aligned. If appropriate to the media, a small amount of mineral oil lubricant may be used on the i.d. of the packing to assist installation. Each ring should be firmly tamped home using an appropriate tool. Joints of successive rings should be staggered by a minimum of 90 degrees. If applicable ensure any lantern rings are replaced in the correct position i.e. adjacent to the pipe tap hole.

After the last ring has been installed bring the gland follower into position and finger tighten the follower nuts. In three stages, using a calibrated torque wrench, tighten the follower nuts to 30%, 60% and then 100% of the predetermined torque value.

If no torque value has been advised, then the packing should only be lightly tightened in the first instance until the running in procedure is followed.

STAGE 6 – Running In

Start the primed pump. At the first sign of leakage tighten the follower nuts until leakage is reduced to an acceptable / controlled level. Ensure that any tightening action results in even compression of the packing. At this stage Do not stop the leakage entirely, this will result in damage to the packing and/or the pump shaft. Gradually increase compression on the packing over the next hour or so, this will greatly improve seal life and efficiency. Routinely feel the gland housing during this period for any increase in temperature; the gland should run cool throughout the running in period. At NO time should the pump run dry.

Pre-Compression of Pump Packing – General Guide

Pump packings should have a minimum compression of 0.5 MPa to 1.5 MPa. Ideally, pump packings should be compressed with a gland pressure of 1.1 to 2 times the media pressure.

Note: These instructions are guidelines only. Site health and safety protocols and site procedures should be followed at all times.

Calculation of Packing Length (L)

When cutting a length of packing in isolation to the equipment or mandrel, the following calculation can be used to determine the length of packing required to produce a ring of the correct size.

$$\text{Length } L = 3.3 * (d + c) \text{ (mm)}$$

$$\text{Packing Section 'c' } = (D - d) / 2$$

D = stuffing box diameter (mm)

d = shaft of spindle diameter (mm)

Cutting and Installation of Compression Packing Rings

(Use of a mandrel or shaft.)

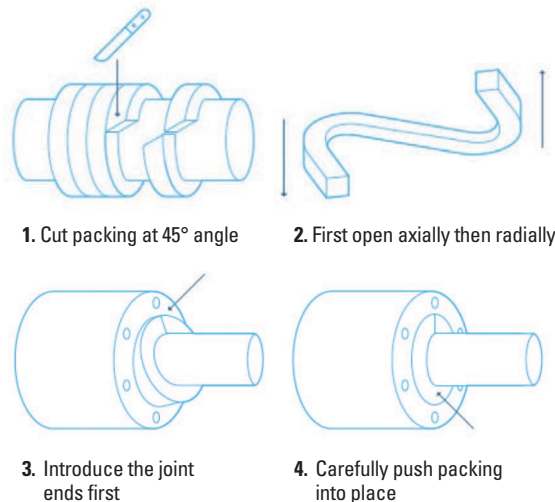

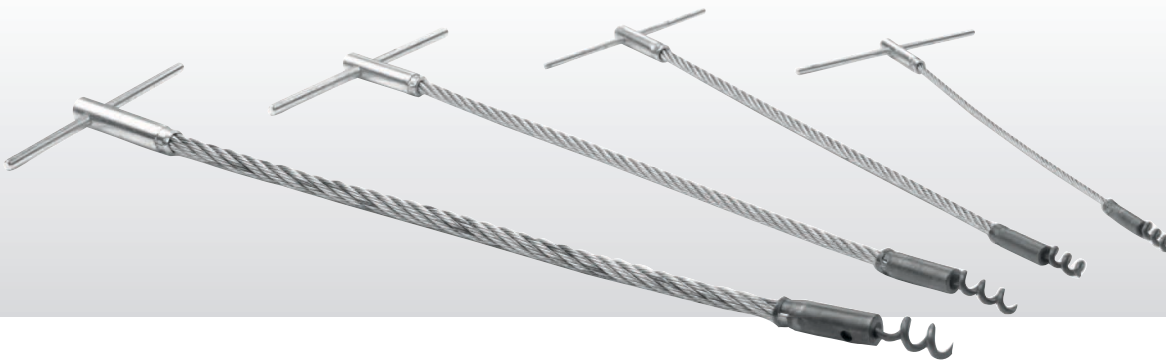

TOOLS OF THE TRADE - EXTRACTION TOOLS

Flexible Packing Extractors are used to assist in the removal of old compression packing from either pump or valve stuffing boxes. The extractors have 'corkscrew' formed tips that are designed to screw into and grip all types of packing, including hardened or heavily worn materials. The 'T-bar' handle located on the end of a long flexible shaft provides the operator with a good grip and assists in gaining easy access into restricted and difficult to reach stuffing boxes.

Each set of extractors consists of four standard sizes:

Size 1:	Suitable for 5.0 – 6.5mm section packing
Size 2:	Suitable for 8.0 – 10.0mm section packing
Size 3:	Suitable for 11.0 – 16.0mm section packing
Size 4:	Suitable for 19.0mm section packing and above.

Other tools that are considered to be important when working with compression packings on a regular basis include:

Cutting Board:
Ring packing cutter.

Packing Knife:
Heavy duty sharp knife (use of these will be restricted on site).

Hand-Held Packing Cutter:
Removes the need for a sharp knife.

Tamping Tools / Split Bushes:

Either use specifically sized split bushes to pre-load rings as they are installed or use tamping tools that are prepared for a pump or valve as a when required. Solid or split bushes can be supplied to size in either Carbon or appropriate metal.

Spacer Bushes & Lantern Rings:

These components are used to reduce the actual stuffing box depth and keep the number of packing rings to the optimum required to provide a good seal.

For in-situ repacking of valves the use of **Hydro-pick / Water Jet Extraction** to remove old packings is one of the most effective methods (qualified operatives are required). In addition, it is also recommended to have a **'dry air line'** (non-lubricated air) available to assist in removing any debris and also to dry the stuffing box prior to installing the compression packing or stem set.

For all enquiries please email
customerservice@flexitallic.eu

NOTE: Used packing to be disposed of in a safe and environmentally considerate manner, compliant with national, regional and site / company requirements and regulations.



UNITED KINGDOM

Flexitallic UK Ltd

Scandinavia Mill
Hunsworth Lane
Cleckheaton
West Yorkshire, BD19 4LN
UK
Tel. +44 1274 851273
Fax. +44 1274 300303
www.flexitallic.com

**Branches also in Aberdeen,
Middlesbrough, Ellesmere
Port and South West.**

BENELUX

Flexitallic Benelux BVBA

Smallandlaan 21
2660 Hoboken
BELGIUM
Tel. + 32 3 369 19 68
www.flexitallic.com

CHINA

Flexitallic Gasket Technology (Suzhou) Co., Ltd

Building A, 1868 Guangming Rd
Technological Development Zone
WuJiang Economic 215200
CHINA
Tel. +86 512 6303 2839
Fax. +86 512 6303 2879
www.flexitallic.com

UNITED STATES

Flexitallic US LLC

6915 Highway 225
Deer Park
Texas 77536
USA
Tel. +1 281 604 2400
Fax. +1 281 604 2415
www.flexitallic.com

FRANCE

Siem Supranite

a Flexitallic Company

31-33 Rue de Mogador
75009 Paris
FRANCE
Tel. +33 (0)1 48 88 88 88
Fax. +33 (0)1 47 66 88 44
www.siem.fr

ITALY

Flexitallic Italy Sr.l

Via Leonardo Da Vinci 6B
26020 Ticengo CR
ITALY
Tel. +39 0374 71006
Fax. +39 0374 71277
www.flexitallic.com

SINGAPORE

Flexitallic Ltd

Singapore Branch

Level 42 Suntec Tower Three
8 Temasek Boulevard
SINGAPORE
038988
Tel. +65 68663638
www.flexitallic.com

UNITED STATES

Custom Rubber Products

2625 Bennington
Houston
Texas 77093
USA
Tel. +1 713 691 2211
Fax. +1 713 691 3005
www.customrubber.com

GERMANY

Flexitallic GmbH

Halskestr. 4a
47877 Willich
GERMANY
Tel. +49 (0) 2154 95363-0
Fax. +49 (0) 2154 95363-29
www.flexitallic.com

UNITED ARAB EMIRATES

Flexitallic LLC

PO Box No. 6591-Al Jazeera
Plot 108, Road E, Al Hamra Industrial
Ras Al Khaimah
UNITED ARAB EMIRATES
Tel. +971 (0)7 243 4305
Fax. +971 (0)7 243 4306
www.flexitallic.com

THAILAND

Flexitallic Sealing Technology Co Ltd

No. 7/456, Moo 6,
Amata City Rayong Industrial Estate
Mabyangporn Sub-district
Pluak Daeng District,
Rayong Province
THAILAND
Tel. +66 (0)33017561 ~ 3
Fax. +66 (0)33017564
www.flexitallic.com

CANADA

Flexitallic Canada Ltd

4340 - 78 Avenue
Edmonton
Alberta, T6B 3J5
CANADA
Tel. +780 466 5050
Fax. +780 465 1177
www.flexitallic.com

About The Flexitallic Group

The Flexitallic Group is a global leader in specialised sealing solutions and products serving the oil and gas, power generation, chemical and petrochemical industries in emerging and developed markets. Focused on the upstream, downstream and power generation sectors, it has operations in France, the United States, Canada, Mexico, the United Kingdom, Germany, Italy, Belgium, the United Arab Emirates, Thailand and China plus a network of worldwide licensing partners and distributors.

www.theflexitallicgroup.com